

CPS Menuboard D2P 46 - 65"
Art.-Nr. / Item no.: 3316

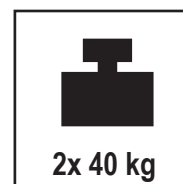
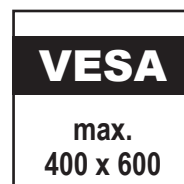
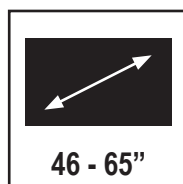

DE

Achtung!

Technische Geräte stellen einen beträchtlichen Wert dar. Sie sollten daher bei der Installation vorsichtig mit den Komponenten umgehen und diese bei Bedarf schützen.

Auch sollte, falls nötig, der Installtionsbereich abgesichert werden. Herabfallende Teile können zu Verletzungen und Materialschäden führen.

Die im Lieferumfang enthaltenen Materialien sind unter Umständen nicht für die speziellen Gegebenheiten am Installationsort geeignet. Bitte prüfen Sie dies vorab und ersetzen Sie diese bei Bedarf durch geeignete Materialien. Für Schäden, die durch eine unsachgemäße Installation entstehen, übernehmen wir keine Haftung.

Falls Sie Bezüglich der Angaben in dieser Installationsanleitung unsicher sind oder noch Fragen haben wenden Sie sich an uns oder anderes ausgebildetes Fachpersonal.

GB

Caution!

Technical devices are of considerable value. You should therefore handle the components carefully during installation and protect them if necessary.

If necessary, the installation area should also be secured. Falling parts can cause injuries and material damage.

The materials included in the scope of delivery may not be suitable for the specific conditions at the installation site. Please check this before and replace them with suitable materials if necessary. We accept no liability for damage caused by improper installation.

If you are unsure about the information in these installation instructions or have any further questions, please contact us or another qualified professional.

Lieferumfang | Scope of delivery



A 1x



B 1x

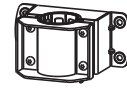

C 1x

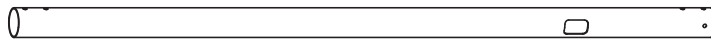

D 1x

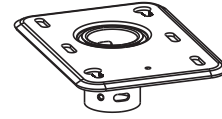

E 1x



F-1 1x



F-2 1x

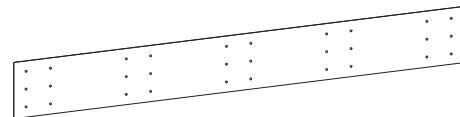

G 1x



H 4x



I 2x



L 6x



O M8x10 2x



J 6x



M 24x



P M8x12 4x



K 1x



N 2x



Q 6x

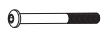

R M8x80 2x



S 2x



T 2x



U 6x



V 4x



M-A 8x
M6x14

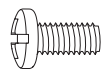

M-B 8x
M8x16



M-C 8x
M6x30



M-D 8x
M8x35



M-E 8x
Ø8



M-F 8x
Ø15xØ8x5



M-G 8x
Ø15xØ8x15

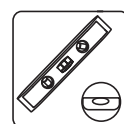
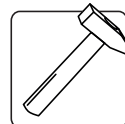
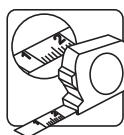
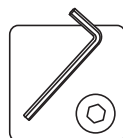

1 Deckenflansche und Rohre verbinden | Connect ceiling plates and pipes

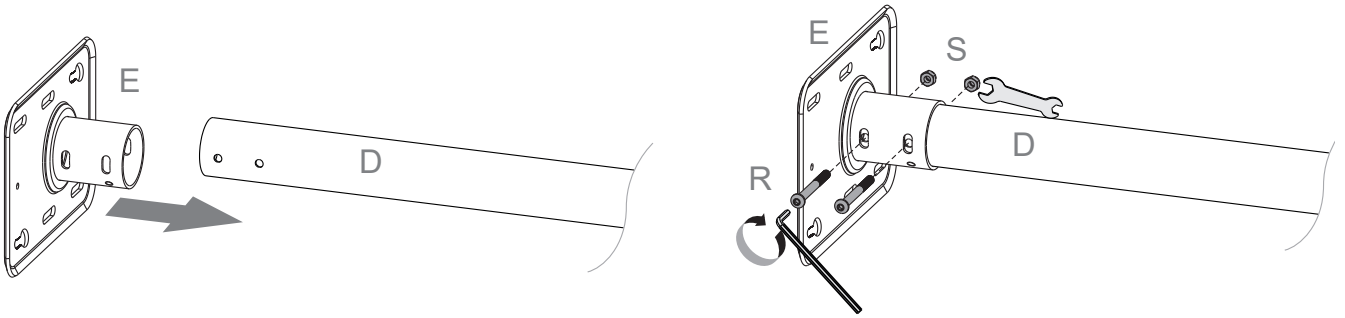

2 Bohrlöcher anzeichnen und setzen | Mark and set drill holes

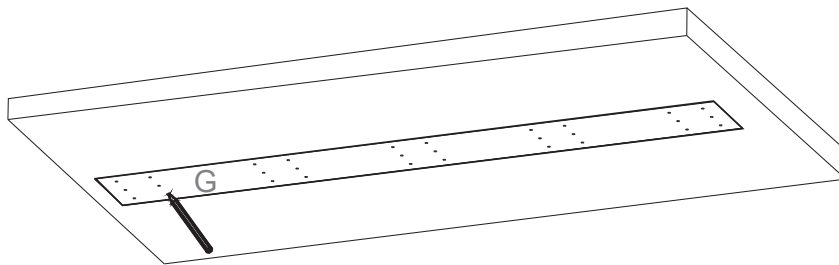
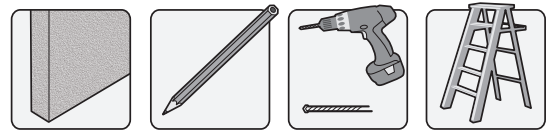
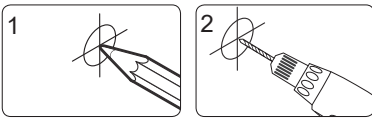

Prüfen Sie vor der Montage die Eignung der Decke!

Check the suitability of the ceiling before installation!

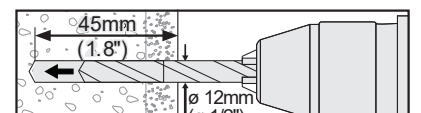

3 Spreizdübel einsetzen | Insert expansion anchors

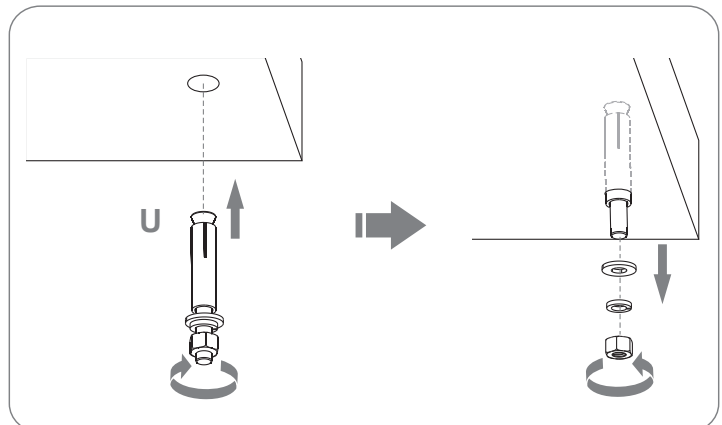
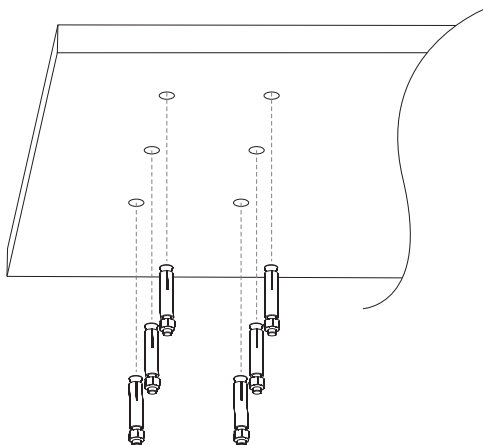

4 Deckenmontage der Deckenflansche | Ceiling mounting of the ceiling plates

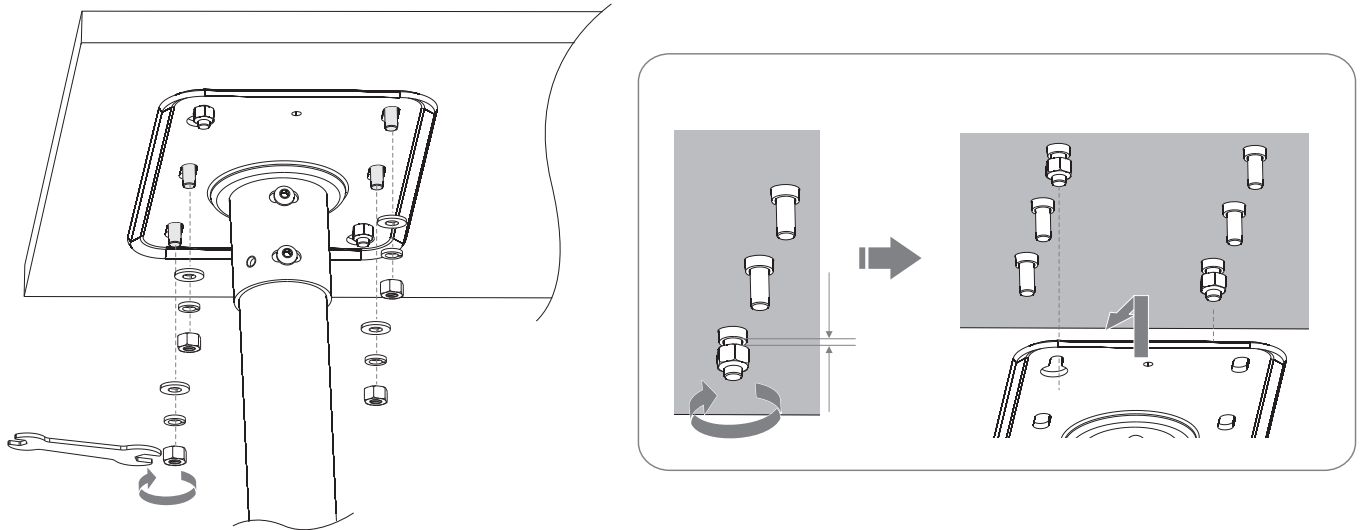

Montieren Sie die Sechskantmuttern an den entsprechenden Spreizdübeln zum Schlüssellochmuster auf der Deckenplatte. Nicht zu fest anziehen und einen kleinen Spalt lassen, damit die Deckenplatte in die Schlüssellochschlitze geschoben werden kann.

Attach the hex nuts to the expansion bolts corresponding to the keyhole pattern found on the ceiling plate. Do not overtighten and leave a small gap so the ceiling plate will slide into the keyhole slots.

5 Abdeckungen aufsetzen | Put on the covers

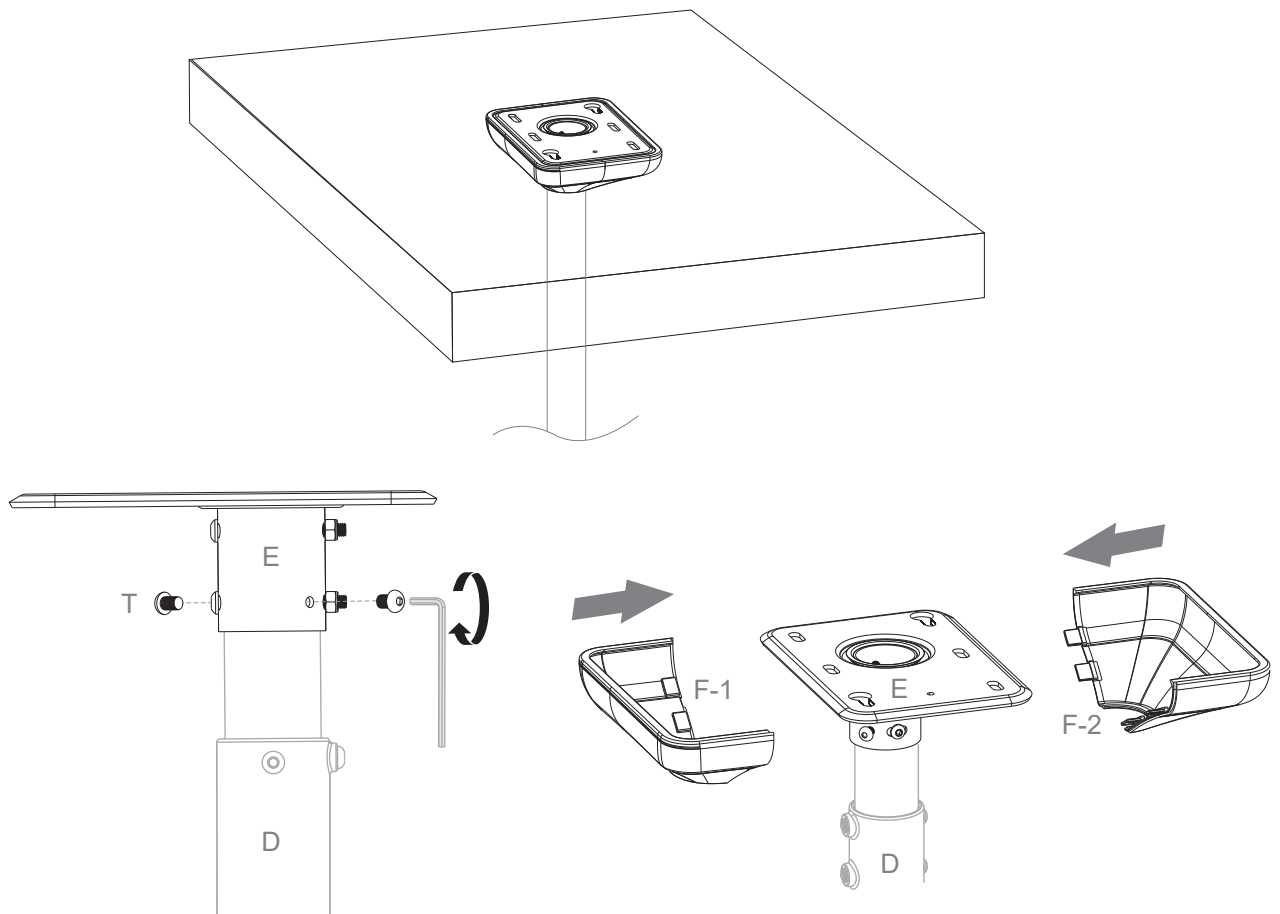

i Abdeckung öffnen | Open the cover

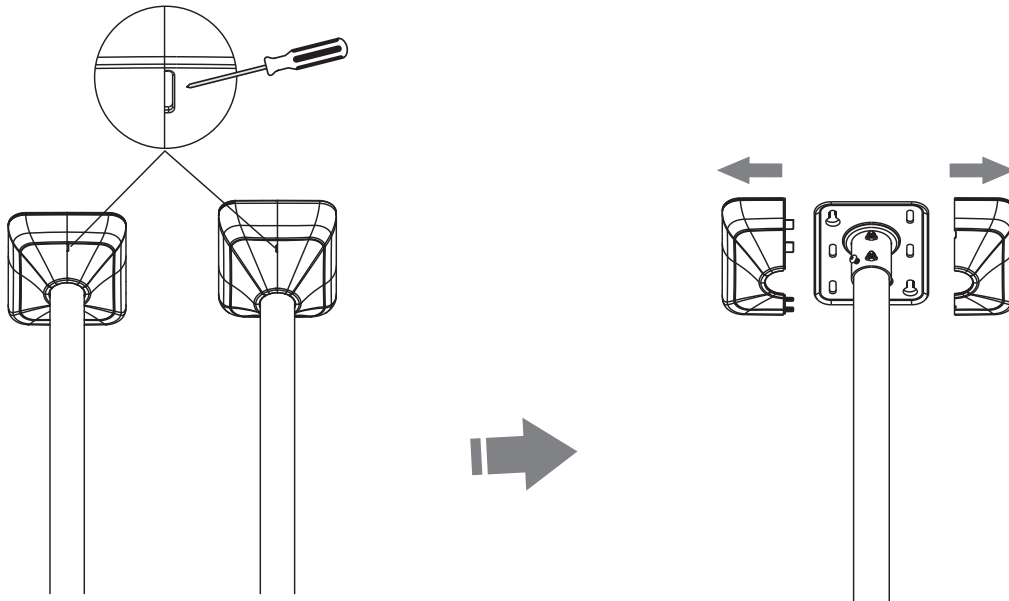

6 Rails verbinden | Connecting rails

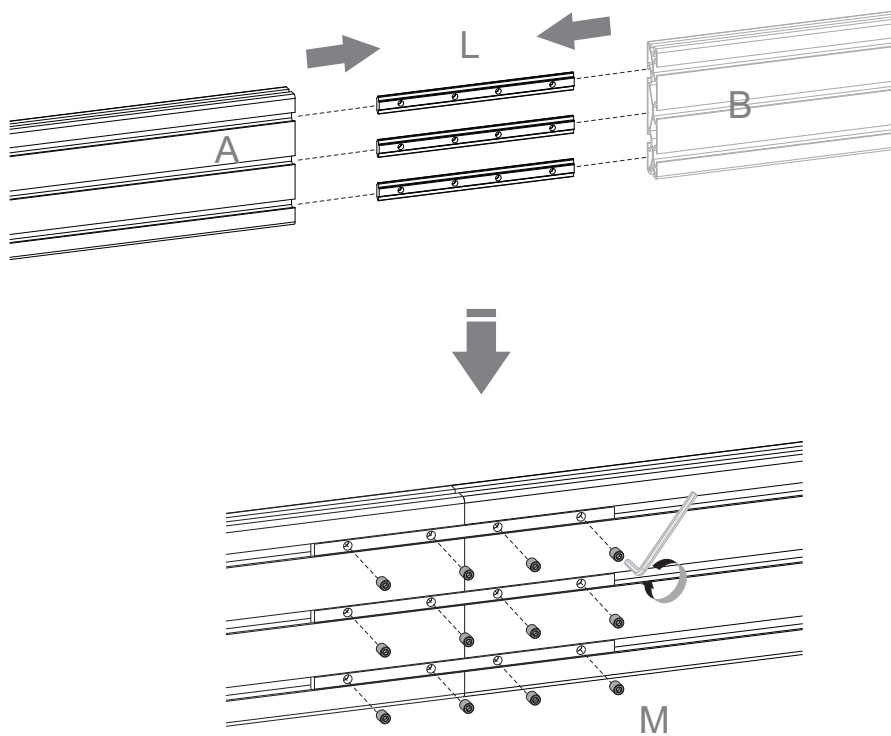

7 Adapter und Rails verbinden | Connect adapters and rails

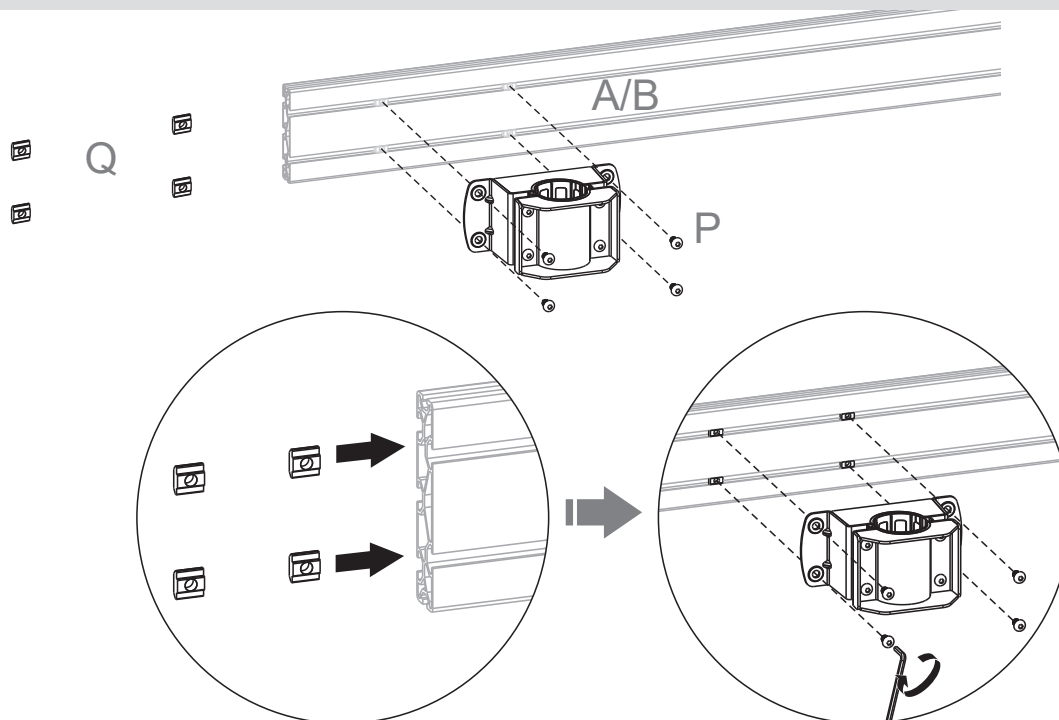

8 Deckenhalterungen und Rails verbinden | Connect ceilingmounts and rails

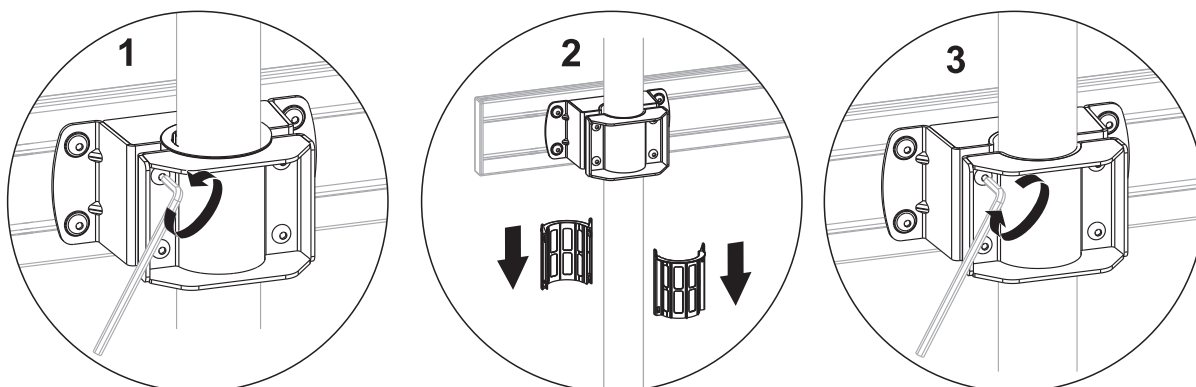
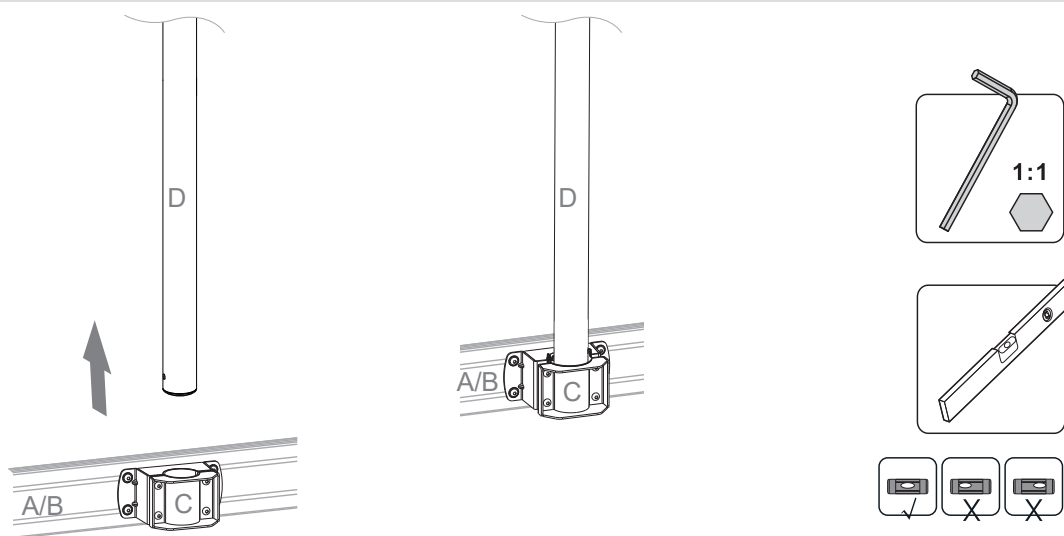

9 Endkappen aufsetzen | Put on end covers

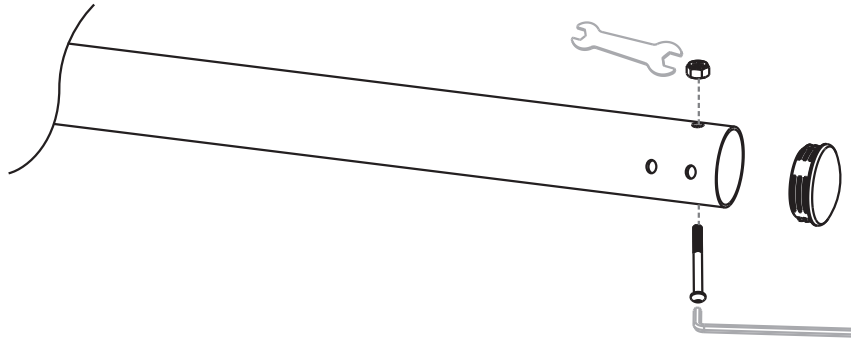

10 Endkappen aufsetzen | Put on end covers

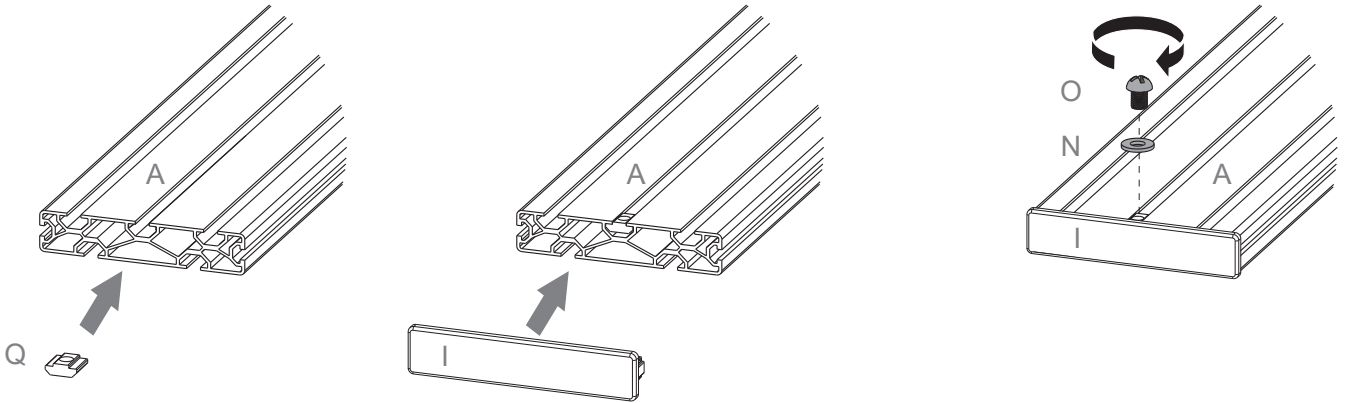

11 VESA-Arme montieren | Mount the VESA arms

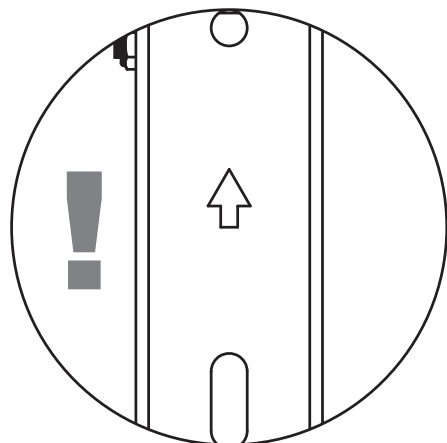
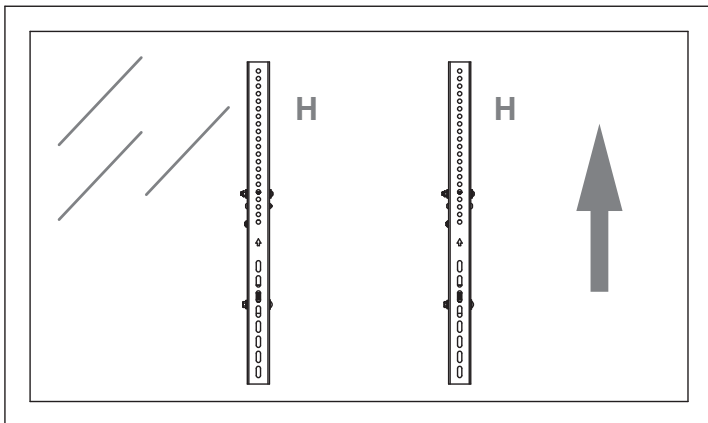

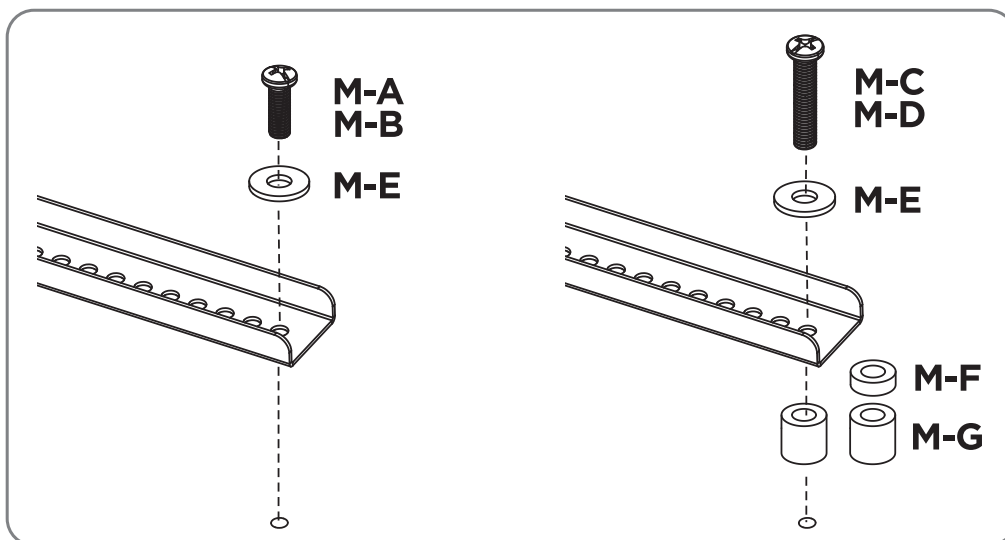
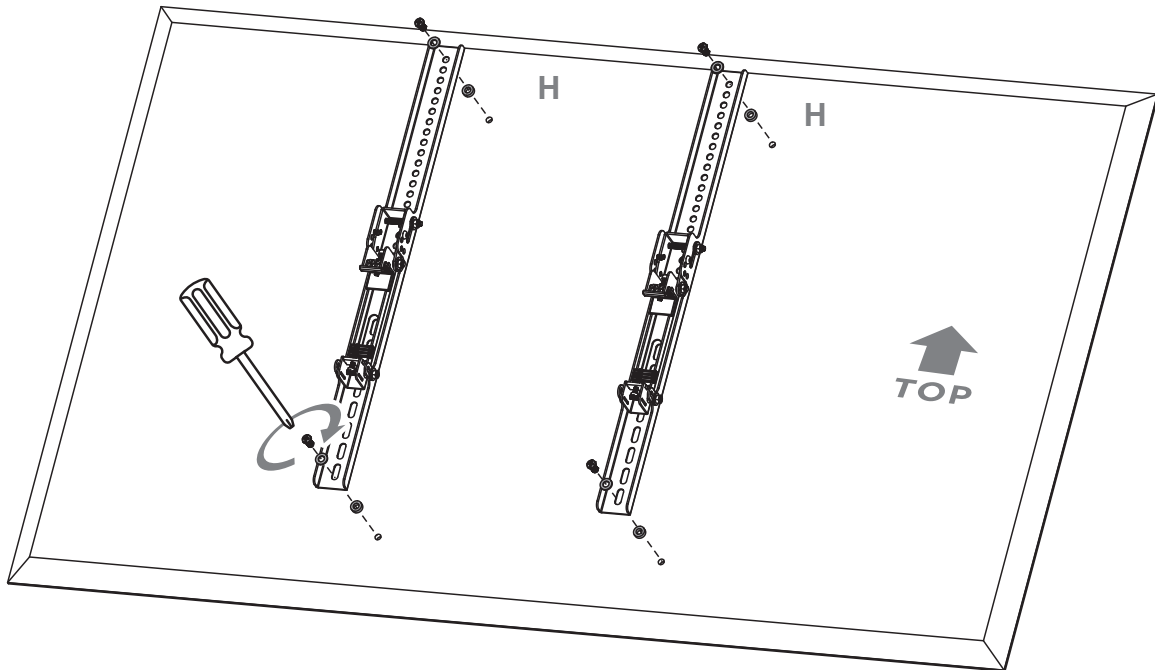
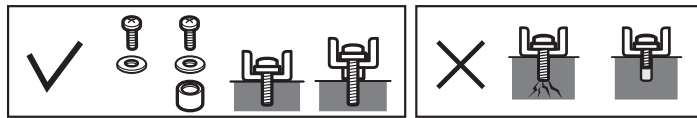

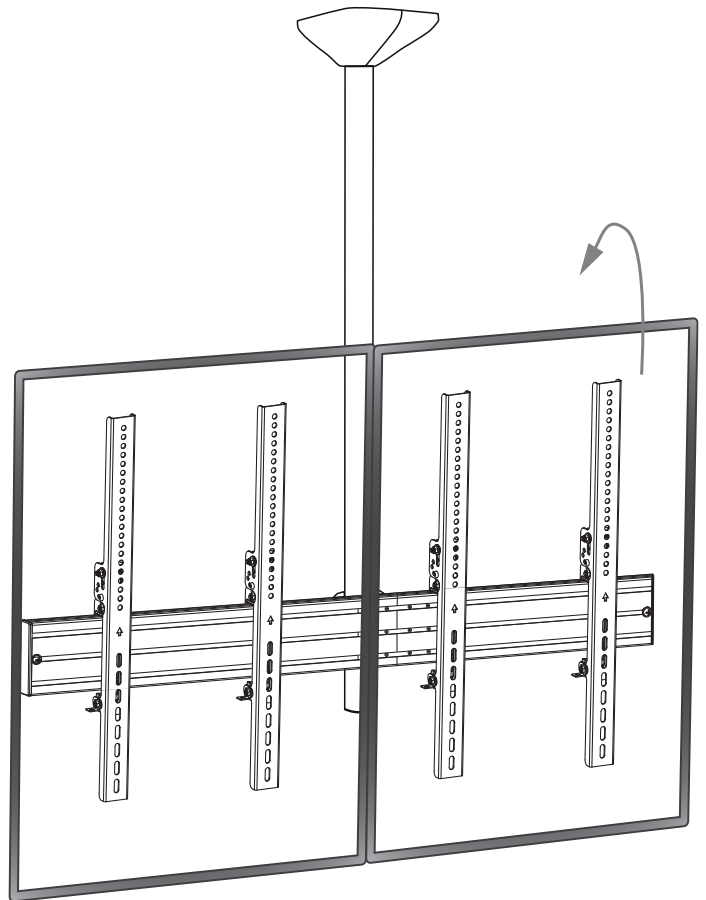
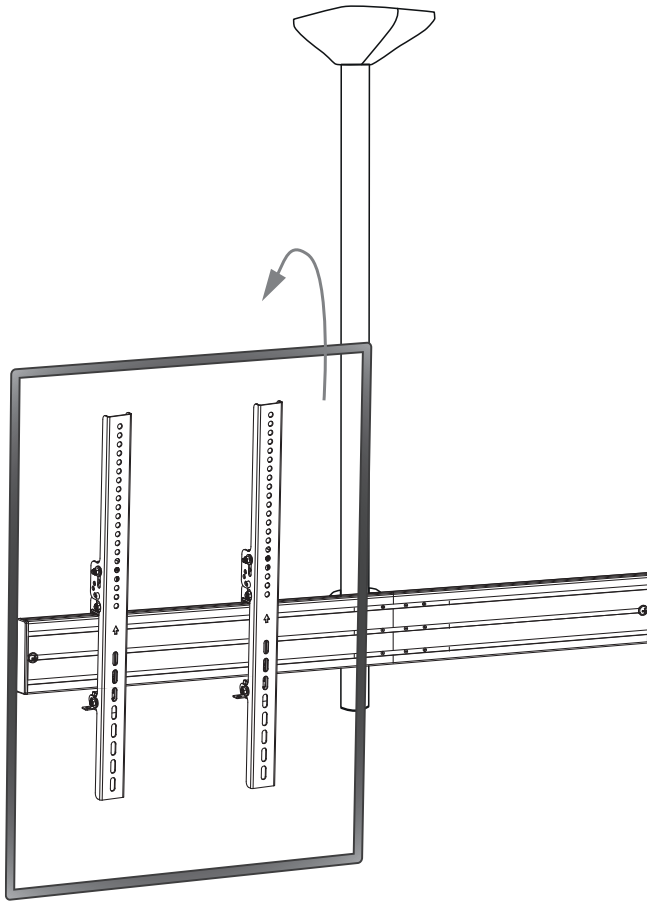

13 Sicherungsschrauben | Locking screws

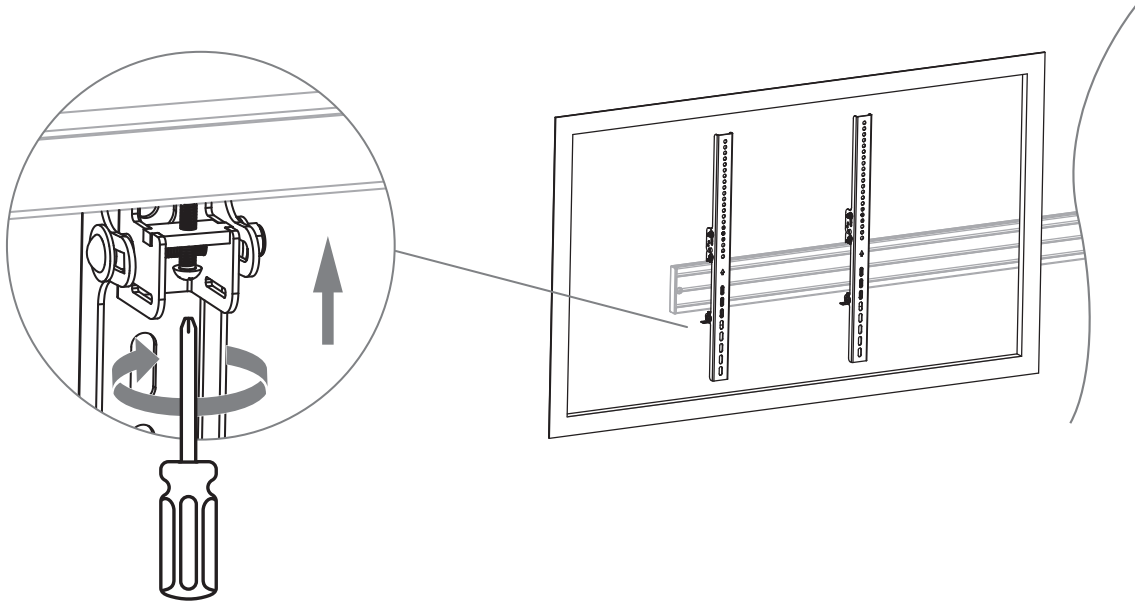

14 Höhenjustage | Height adjustment

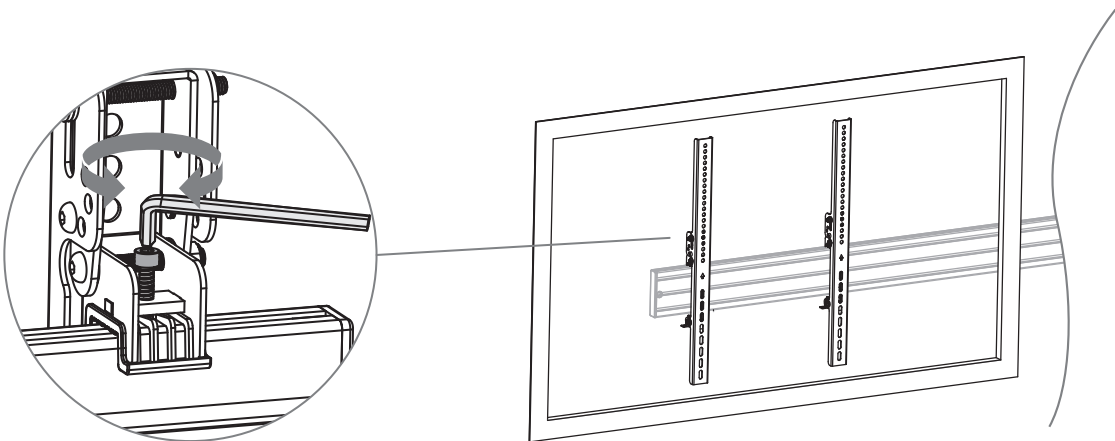

15 Neigungseinstellung | Tilt adjustment

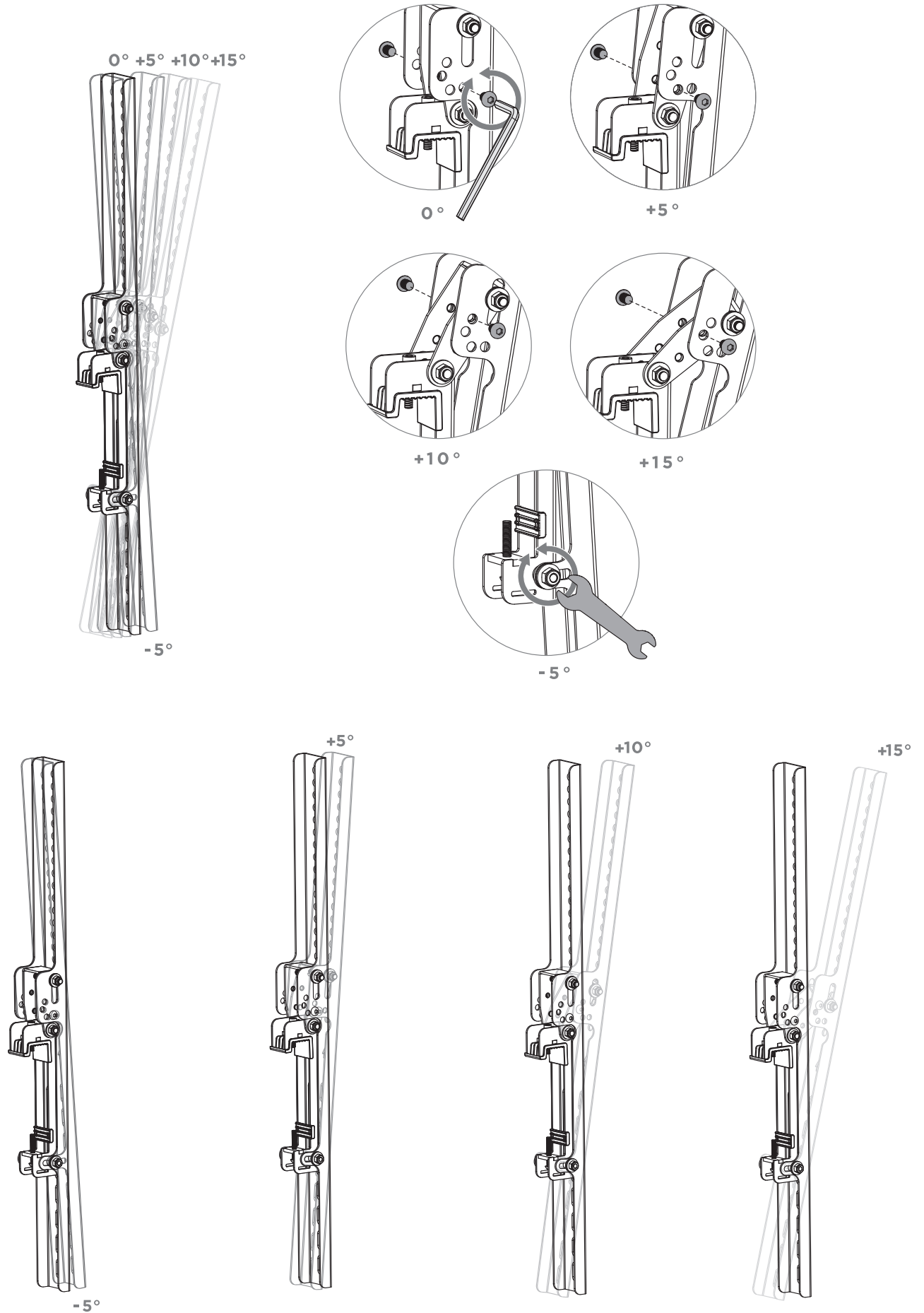

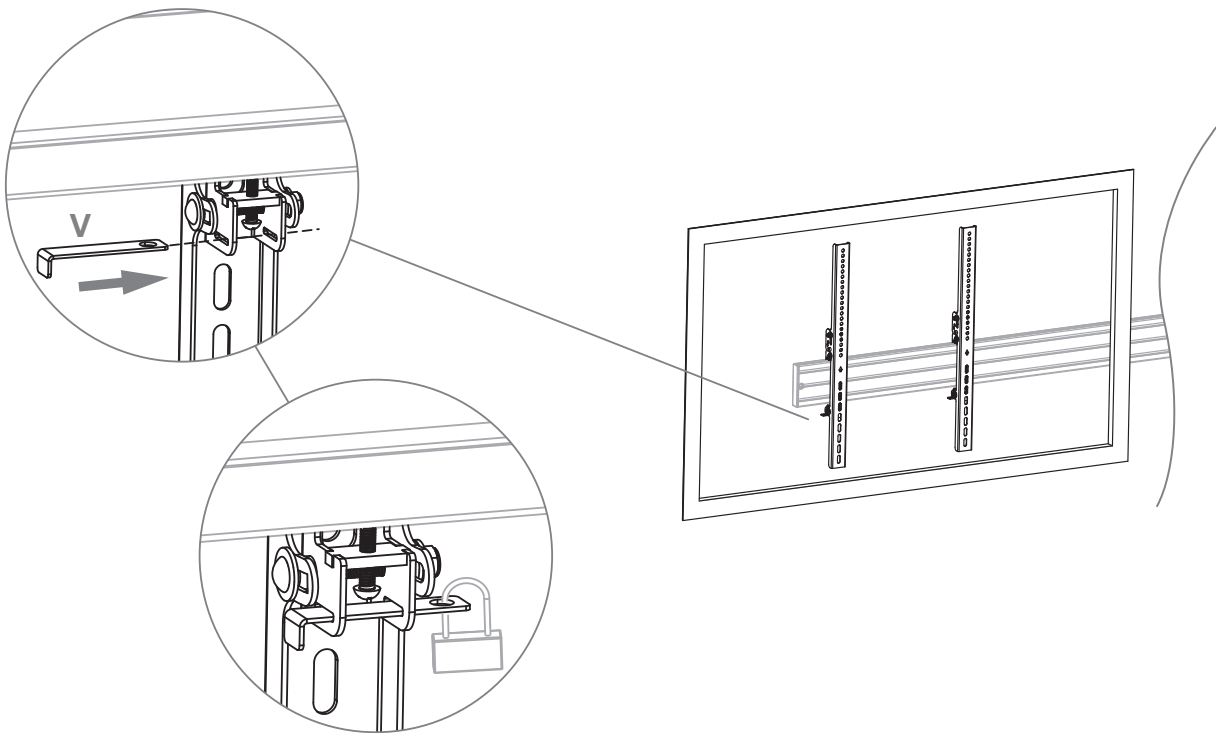
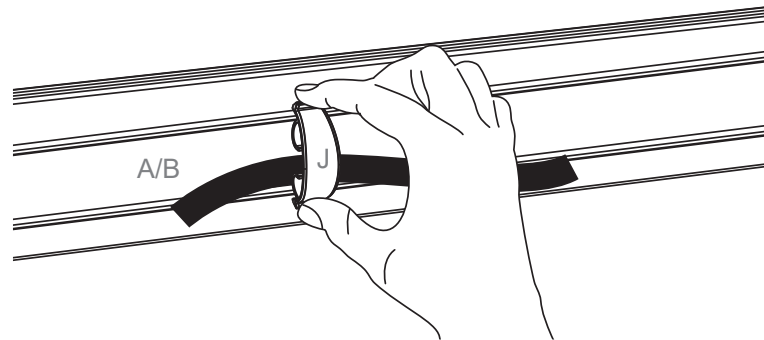

Das Vorhängeschloss ist nicht im Lieferumfang enthalten.

The padlock is not included.

Abmessungen | Dimensions

